

PROPRIETARY AND CONFIDENTIAL  
 THE INFORMATION CONTAINED IN THIS  
 DRAWING IS THE SOLE PROPERTY OF  
 JSB TECH PTE LTD. ANY  
 REPRODUCTION IN PART OR AS A WHOLE  
 WITHOUT THE WRITTEN PERMISSION OF  
 JSB TECH PTE LTD IS  
 PROHIBITED.

		UNLESS OTHERWISE SPECIFIED:		NAME	DATE
		DIMENSIONS ARE IN MM	DRAWN	KUU	10/04/13
		TOLERANCES:	CHECKED		
		FRACTIONAL ±	ENG APPR.		
		ANGULAR: MACH ± BEND ±	MFG APPR.		
		TWO PLACE DECIMAL ±	Q.A.		
		THREE PLACE DECIMAL ±	COMMENTS:		
		INTERPRET GEOMETRIC TOLERANCING PER:			
		MATERIAL PC/ABS CAST IRON			
		FINISH			
NEXT ASSY	USED ON				
APPLICATION		DO NOT SCALE DRAWING			

ALL DIMENSION IN MM

TITLE:		
<b>DWL8500XY</b>		
SIZE	DWG. NO.	REV
<b>A</b>	2013-04-1101	
SCALE: 1:1	WEIGHT:	SHEET 1 OF 2

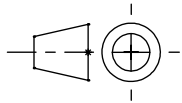
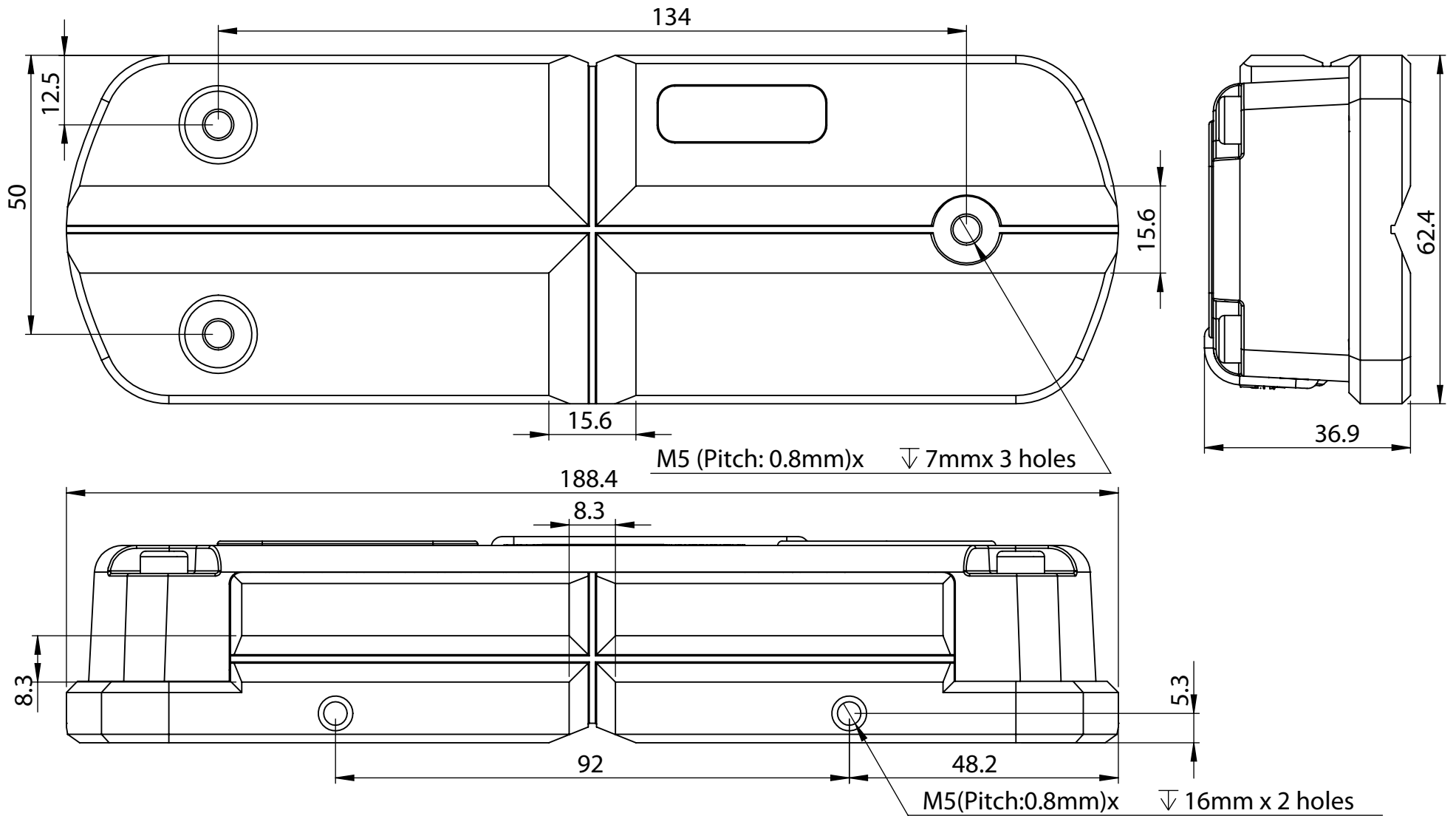

PROPRIETARY AND CONFIDENTIAL  
 THE INFORMATION CONTAINED IN THIS  
 DRAWING IS THE SOLE PROPERTY OF  
 JSB TECH PTE LTD. ANY  
 REPRODUCTION IN PART OR AS A WHOLE  
 WITHOUT THE WRITTEN PERMISSION OF  
 JSB TECH PTE LTD IS  
 PROHIBITED.

		UNLESS OTHERWISE SPECIFIED:		NAME	DATE
		DIMENSIONS ARE IN MM		DRAWN	KUU 10/04/13
		TOLERANCES:		CHECKED	
		FRACTIONAL $\pm$		ENG APPR.	
		ANGULAR: MACH $\pm$ BEND $\pm$		MFG APPR.	
		TWO PLACE DECIMAL $\pm$		Q.A.	
		THREE PLACE DECIMAL $\pm$		COMMENTS:	
		INTERPRET GEOMETRIC TOLERANCING PER:			
		MATERIAL	PC/ABS CAST IRON		
		FINISH			
NEXT ASSY	USED ON				
APPLICATION		DO NOT SCALE DRAWING			

ALL DIMENSION IN MM

TITLE:

**DWL8500XY**

SIZE	DWG. NO.	REV
<b>A</b>	2013-04-1102	

SCALE: 1:1	WEIGHT:	SHEET 2 OF 2
------------	---------	--------------